

TRATO SE 5080 LED

Architectural line

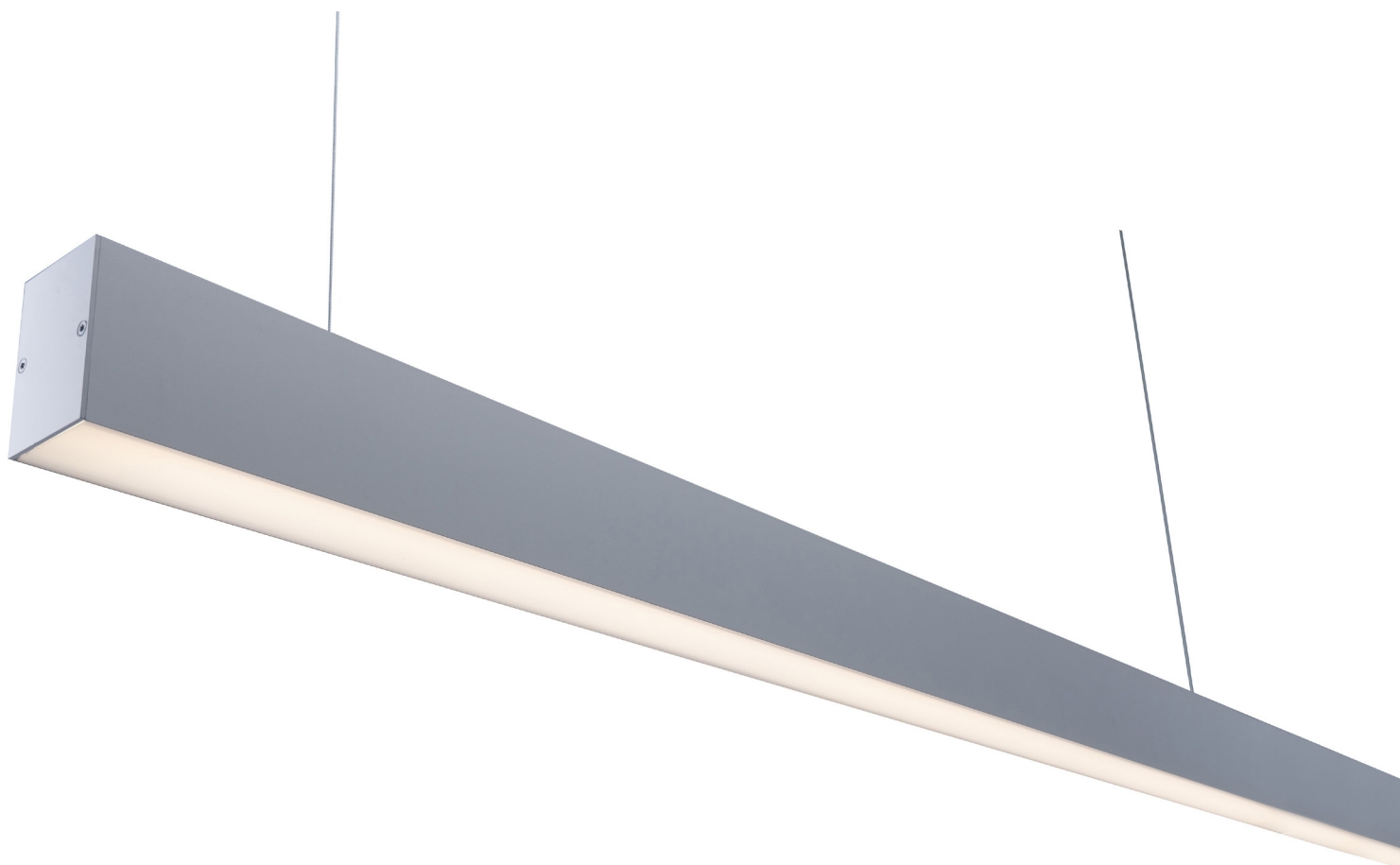

TRATO SE 5080 LED

Lighting system for linear LED Module, maximum 13 432 lumens / meters

- Installation: suspended, LO or LI recessed, ceiling mounted
- Independant elements or elements for beginning, intermediare or end for continuous lighting up to 40 meters
- CRI of 80
- MacAdam ellipse : 3 SDCM
- Available in 3 000 K and 4 000 K
- 50 000 hours lamp life (L80B20)
- Luminous efficiency of system up to 162,8 lm/W
- Optics available in rolls up to 50 meters (10, 20, 30, 40 or 50 meters) in predefined lenght (1 120 mm, 1 680 mm, 2 240 mm and 3 360 mm)
- Opal diffuser made of polycarbonate (DO) or microprism diffuser (MIC)
- Housing made of painted extruded aluminium profil
- Painted steel endcaps
- Static heat sink
- **Weight:** approx. 5 kg / m
- **Number of module(s):** Depend on the lenght of the luminaire
- **Driver(s):** Fixed, Dimmable driver DALI (CDIMMDALI)
- **Accessories:** Suspension kit
- **Option(s):** Suspended luminaire with indirect lighting, 90° angle, lighting sensor and-or movement detection

Driver(s)



Standards

Class I | IK07 | 650°

Beam(s)

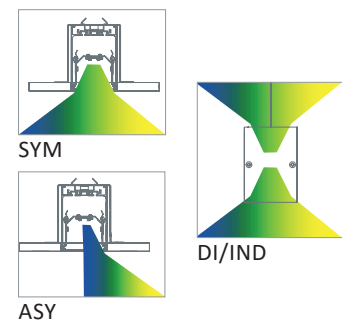

LED configuration recommended for **commercial use**

ITEM	LENGTH (MM)	POWER	CONSUMPTION	LUMINOUS FLUX	SYSTEM EFFICIENCY	COLOUR TEMPERATURE	CRI	EFFICIENCY ENERGY CLASS
SE 5080 LED 4400-830	1120	25W	29W	4345 lumens	149,5 lm/W	3000	80	C
SE 5080 LED 4400-840	1120	25W	29W	4574 lumens	157,3 lm/W	4000	80	C
SE 5080 LED 6600-830	1680	36,6W	42W	6380 lumens	151,6 lm/W	3000	80	C
SE 5080 LED 6600-840	1680	36,6W	42W	6716 lumens	159,6 lm/W	4000	80	C
SE 5080 LED 8800-830	2240	50W	58W	8690 lumens	149,5 lm/W	3000	80	C
SE 5080 LED 8800-840	2240	50W	58W	9148 lumens	157,3 lm/W	4000	80	C
SE 5080 LED 13000-830	3360	73,2W	84W	12760 lumens	151,6lm/W	3000	80	C
SE 5080 LED 13000-840	3360	73,2W	84W	13432 lumens	159,6 lm/W	4000	80	C

LED configuration recommended for **office use** (UGR<19 with microprismatic optics)

ITEM	LENGTH (MM)	POWER	CONSUMPTION	LUMINOUS FLUX	SYSTEM EFFICIENCY	COLOUR TEMPERATURE	CRI	EFFICIENCY ENERGY CLASS
SE 5080 LED 2250-830	1120	12,1W	15,5W	2232 lumens	143,8 lm/W	3000 K	80	C
SE 5080 LED 2250-840	1120	11,2W	14,4W	2197 lumens	153 lm/W	4000 K	80	C
SE 5080 LED 3400-830	1680	17,7W	21,3W	3276 lumens	153,6 lm/W	3000 K	80	C
SE 5080 LED 3400-840	1680	16,8W	20,2W	3295 lumens	162,8 lm/W	4000 K	80	C
SE 5080 LED 4500-830	2240	24,2W	31W	4464 lumens	143,8 lm/W	3000 K	80	C
SE 5080 LED 4500-840	2240	22,4W	28,8W	4394 lumens	153 lm/W	4000 K	80	C
SE 5080 LED 6800-830	3360	35,4W	42,6W	6552 lumens	153,6 lm/W	3000 K	80	C
SE 5080 LED 6800-840	3360	33,6W	40,4W	6590 lumens	162,8 lm/W	4000 K	80	C

TRATO SE 5080 LED

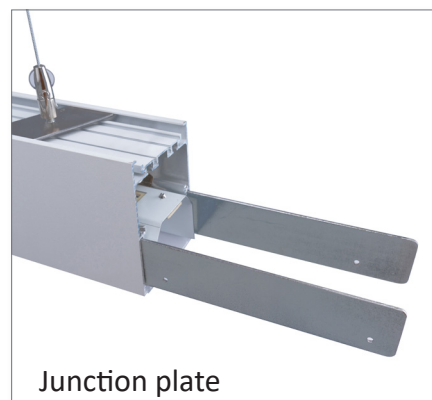
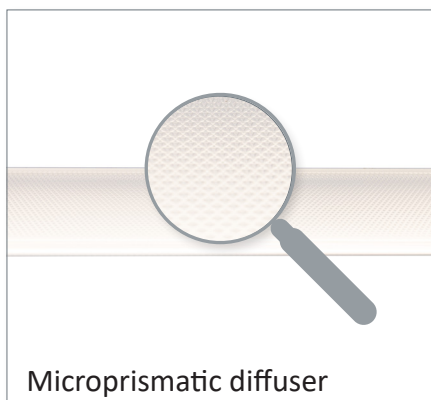

The rolls are delivered in lengths of 10, 20, 30, 40 or 50 meters, which enables to install the diffuser on the whole length, without interruption.

1- Trimless recessed

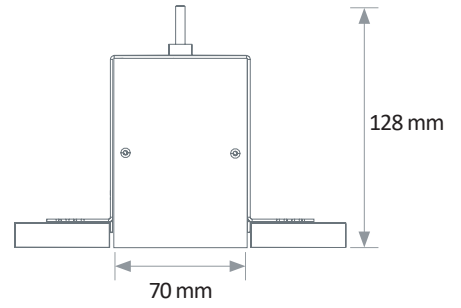
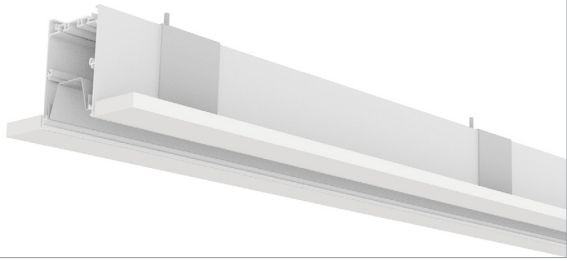

2- Ceiling mounted

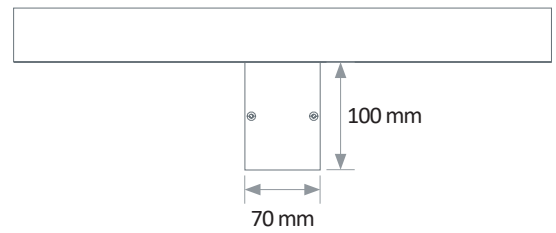
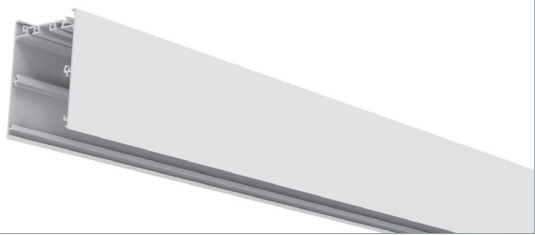

3- Recessed Lay-in

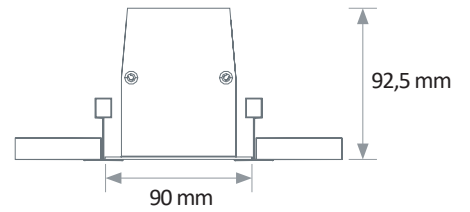

4- Recessed Lay-out

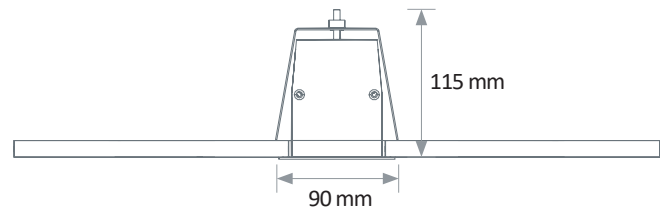
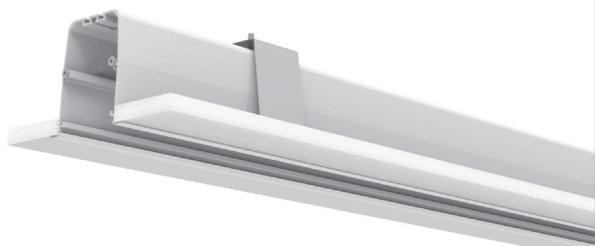

5- Suspended

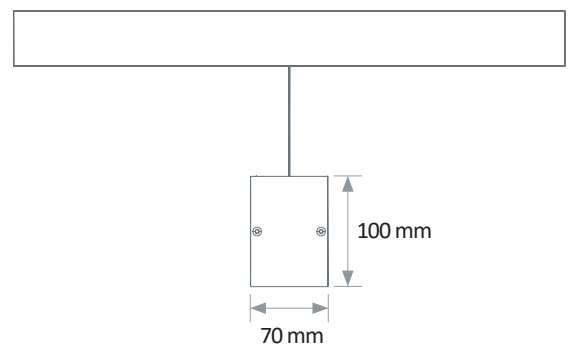
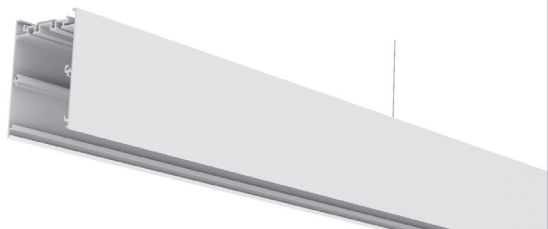

TRATO SE 5080 LED



TRATO SE 5080 LED

The technological innovation for buildings and users

The SE 5080 LED lighting system is equipped with the last technological innovations regarding the control in order to optimize energy savings and to reduce maintenance costs.

Whether for new building or renovation, the SE 5080 LED meets the latest standards in terms of energy consumption without compromising user comfort, and offers maximum flexibility of use.

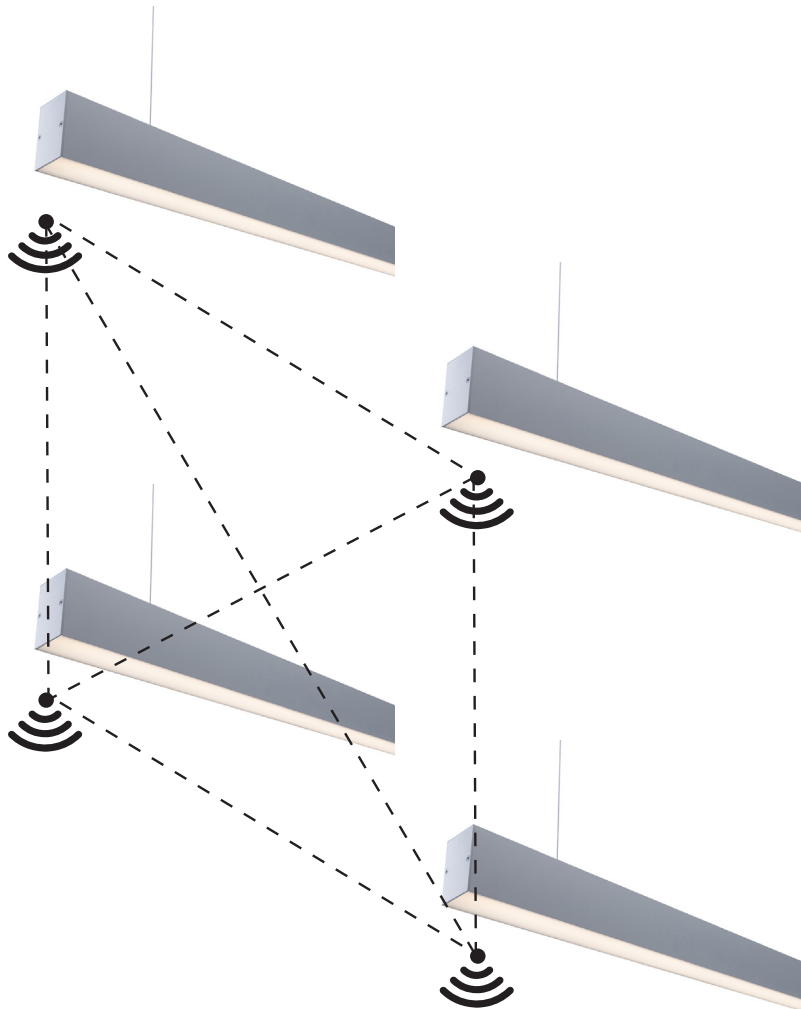

The SE 5080 LED can be equipped with a wireless or wired control solution and be operated as a stand-alone unit.

It can also be equipped with a certified DALI-2 captor (<https://www.dali-alliance.org/dali2/>) and becoming the ideal lighting system for a control from the building management system (BMS).



The use of certified DALI drivers by 251, 252, and 253 (<https://www.dali-alliance.org/dali/data.html>) enables the SE 5080 LED to return as much information as possible, truly useful to the management and the maintenance of the system.

To go further you can also equip the SE 5080 LED with sensors for temperature, humidity or air quality.

More than a lighting device, the SE 5080 LED becomes the key element for building management.

Thanks to these features, the SE 5080 LED adapts itself to all the configurations of a tertiary environment.



- Presence detector (PIR)
- Daylight control
- Temperature
- Humidity
- Air pressure and quality



- Individual office
- Open space
- Meeting room
- Corridor
- Refectory



TRATO SE 5080 LED

The technological innovation for buildings and users

Because our needs in lighting change according to age, time of day and tasks to accomplish, being able to adjust the intensity and the colour temperature can greatly improve user comfort.

The integration of *Tunable white* Led sources into the SE 5080 combined to a manual controlling system, allows users to change both the light intensity and the colour temperature at will.



You can also combine the SE 5080 LED *Tunable white* to an HCL autopilot system. So that it can reproduce the natural variation of colour temperature throughout the day, and thus try to reproduce the visual and non-visual light effect as well as possible.

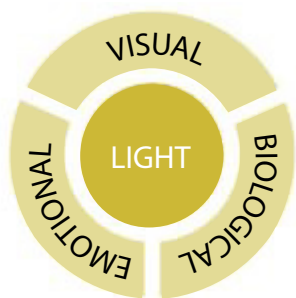

See better



Live better



Feeling better

Rotary button, touch screen, iOS or Android App, there are a multiple of control solution compatible with the SE 5080 LED.

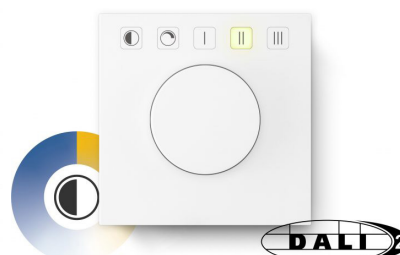

TRATO
Lighting

22, rue Molière - BP369 - 59057 ROUBAIX Cedex 01 (Lille) FRANCE
Tél. : +33 (0) 320 81 50 00 - Fax : +33 (0) 320 81 50 19
Email : contact@trato.fr - Web : www.trato.fr