

EO 5140-C LED ROD



Colour(s)



Ø68 mm



ORIENTABLE AND ADJUSTABLE ■ LED

- Ceiling mounted luminaire for LED SPOT module, maximum 2 400 lumens
- CRI of 95
- MacAdam Ellipse: 2 SDCM
- Available in 3 000 K and 4 000 K
- 50 000 hours lamp life (L80B10)
- Luminous efficiency of system up to 108 lm/W
- Springs in pressure for easier installation
- Ring made of die-cast aluminium
- Silicon lens optics
- **Weight** : Approx. 1,3 kg
- **Driver(s)** : Fixed, Dimmable DALI (CDIMMDALI), Casambi, Connect
- **Option(s)** : Fast connector (CORD)
- Photobiological risk group 1

Driver(s)



Standards

Classe I | IP 20 | 650° | RG1

Beam(s)



Dimensions

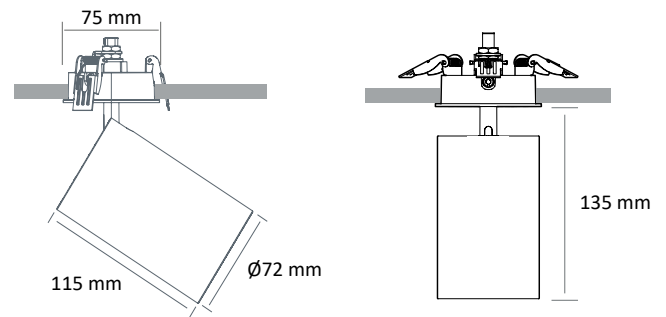

ITEM	POWER	CONSUMPTION	LIGHT EMITTING SURFACE	LUMINOUS FLUX	SYSTEM EFFICIENCY	COLOUR TEMPERATURE	CRI	BEAM	EFFICIENCY ENERGY CLASS
EO 5140-C LED ROD 900-930	13,1 W	16 W	LES4	893 lumens	59,3 lm/W	3000 K	95	7°	F
EO 5140-C LED ROD 1000-940	13,1 W	16 W	LES4	987 lumens	65,5 lm/W	4000 K	95	7°	E
EO 5140-C LED ROD 950-930	8,8 W	11 W	LES6	965 lumens	87,7 lm/W	3000 K	95	10°/20°/35°	F
EO 5140-C LED ROD 1050-940	8,8 W	11 W	LES6	1047 lumens	95,2 lm/W	4000 K	95	10°/20°/35°	D
EO 5140-C LED ROD 1400-930	14,9 W	17,95 W	LES6	1381 lumens	76,9 lm/W	3000 K	95	10°/20°/35°	F
EO 5140-C LED ROD 1500-940	14,9 W	17,95 W	LES6	1498 lumens	83,4 lm/W	4000 K	95	10°/20°/35°	D
EO 5140-C LED ROD 2000-930	17,3 W	19,44 W	LES9	1904 lumens	97,95 lm/W	3000 K	95	15°/20°/35°	F
EO 5140-C LED ROD 2000-940	17,3 W	19,44 W	LES9	2101 lumens	108 lm/W	4000 K	95	15°/20°/35°	E
EO 5140-C LED ROD 2200-930	21,1 W	24,3 W	LES9	2175 lumens	90,5 lm/W	3000 K	95	15°/20°/35°	E
EO 5140-C LED ROD 2600-940	21,1 W	24,3 W	LES9	2400 lumens	99,9 lm/W	4000 K	95	15°/20°/35°	E